



# Building Guide

Colorado Chapter of the International Code Council

## Single Family Residential One Story Detached Garage

### How to Use this Guide

Check with your jurisdiction regarding type of submittal (paper or electronic) and additional requirements. Draw to scale and complete the following (*hint: use graph paper with ¼" squares. Example: ¼" = 1'*).

**1 Complete this Building Guide** by filling in the blanks on page two and four, and indicating which construction details will be used.

**2 Provide 2 Plot Plans** (site plan) showing dimensions of your project and its relationship to existing buildings or structures on the property and the distance to existing property lines, drawn to scale. See page3.

**3 Fill out a building permit application.**

The majority of permit applications are processed with little delay. The submitted documents will help determine if the project is in compliance with building safety codes, zoning ordinances and other applicable laws.

The Colorado Chapter of the International Code Council is a professional organization seeking to promote the public health, safety and welfare to building construction. We appreciate your feedback and suggestions please write to the Colorado Chapter of the International Code Council, P.O. Box 961, Arvada, CO 80001. This building guide can be found on the Colorado Chapter of the International Code Council website at:  
<http://www.coloradochaptericc.org>

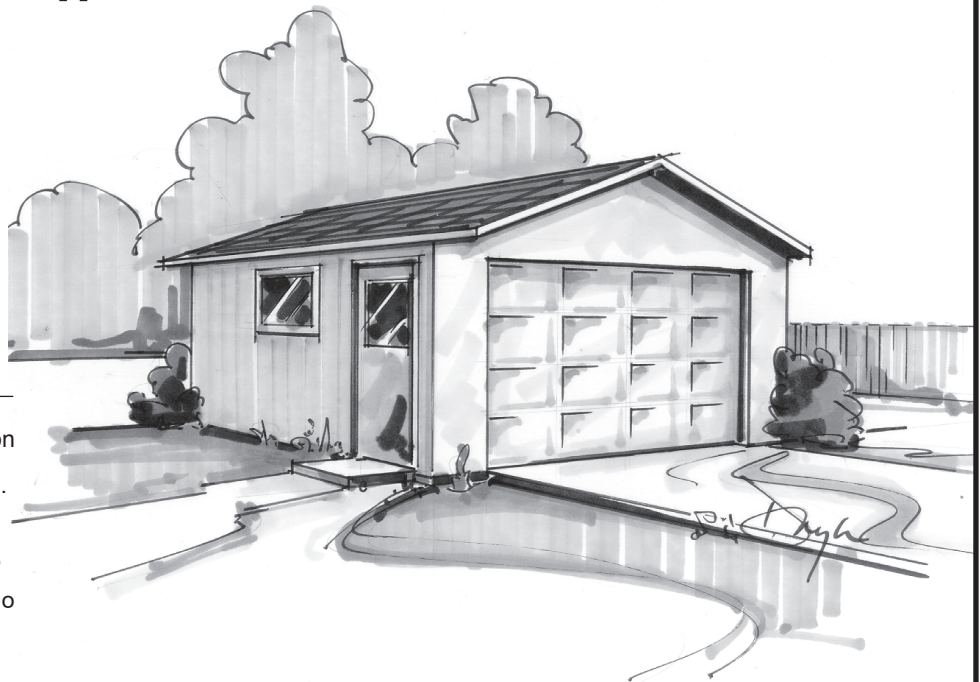

This handout was developed by the Colorado Chapter of the International Code Council as a basic plan submittal under the 2018 International Residential Code. It is not intended to cover all circumstances. Check with your Department of Building Safety for additional requirements.



20120 Mainstreet, Parker, CO 80138  
Phone 303-841-1970 email [building@parkeronline.org](mailto:building@parkeronline.org)

# Single Family Residential One Story Detached Garage

## Directions

1. Fill in the blanks on pages 2 and 4 with dimensions and materials which will be used to build the structure. Please print legibly.

Address: \_\_\_\_\_

2. Indicate in the check boxes on page 4 which details from page 5 will be used.

Note: Heated garages will require insulation, such as ceilings, walls, and foundation.

## Floor Plan

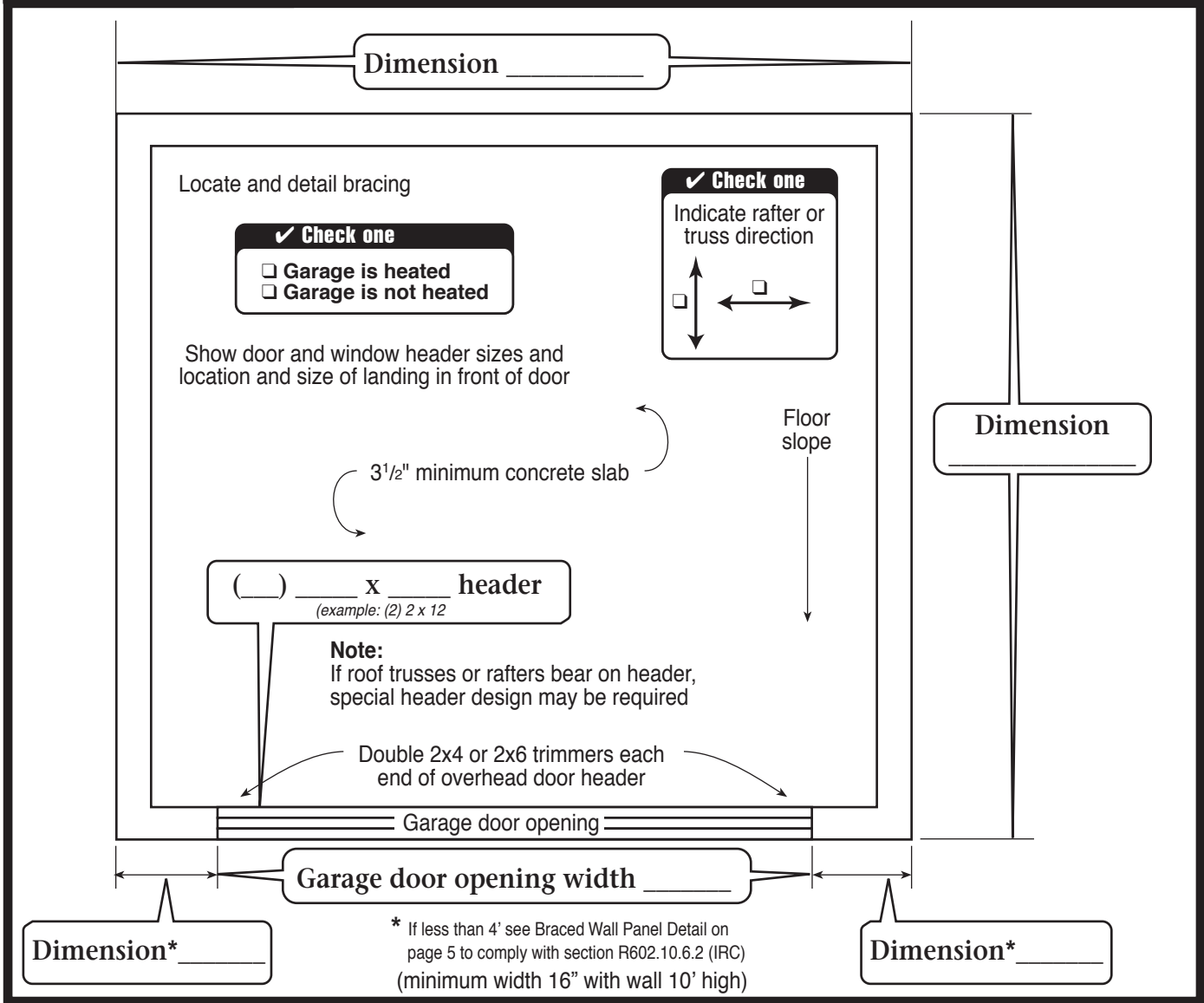

This handout was developed by the Colorado Chapter of the International Code Council as a basic plan submittal under the 2018 International Residential Code. It is not intended to cover all circumstances. Check with your Department of Building Safety for additional requirements.



**PARKER**  
COLORADO

20120 Mainstreet, Parker, CO 80138  
Phone 303-841-1970 email building@parkeronline.org

# Single Family Residential One Story Detached Garage

## Site Plan Example

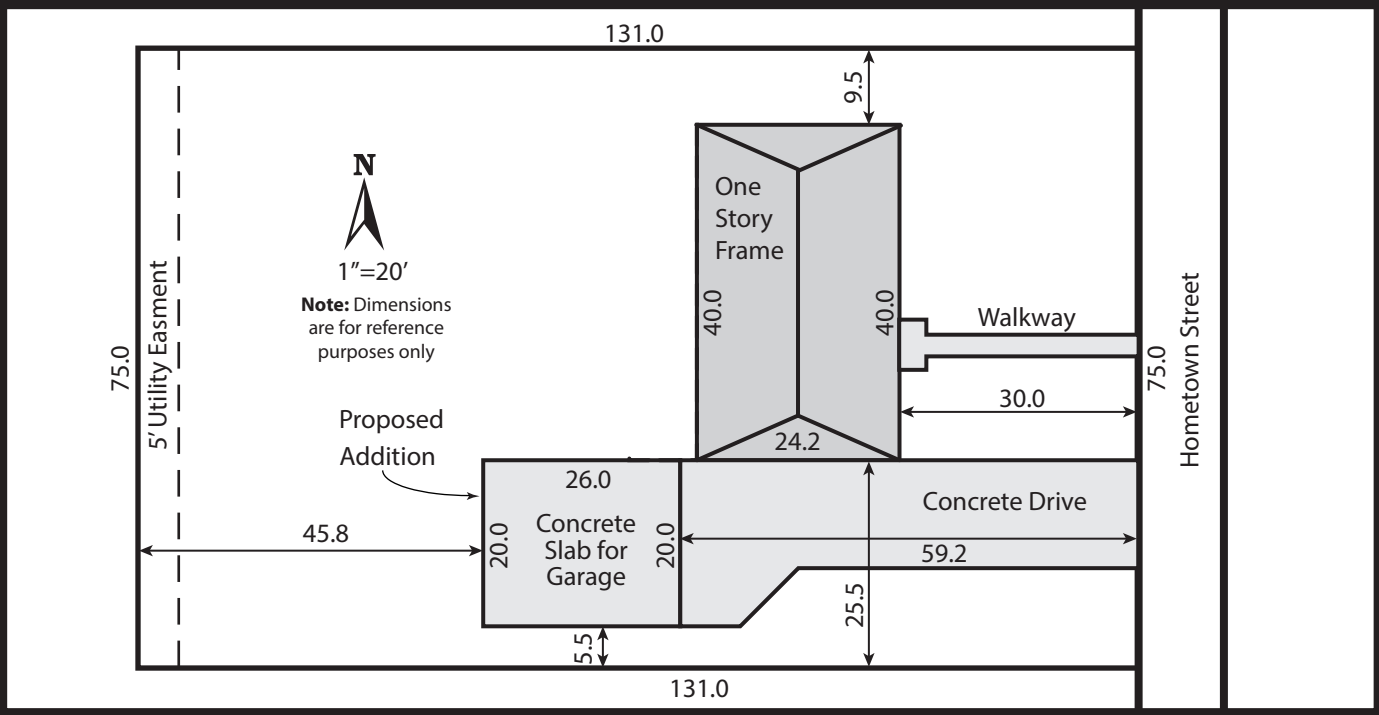

This handout was developed by the Colorado Chapter of the International Code Council as a basic plan submittal under the 2018 International Residential Code. It is not intended to cover all circumstances. Check with your Department of Building Safety for additional requirements.



**PARKER**  
COLORADO

20120 Mainstreet, Parker, CO 80138  
Phone 303-841-1970 email [building@parkeronline.org](mailto:building@parkeronline.org)

# Single Family Residential One Story Detached Garage

Note: For roofs with slopes less than 4:12, follow manufacturer's instructions for low slope application of roofing material.

Truss or 2x \_\_\_\_\_ rafters spaced \_\_\_\_\_" O.C.  
*(example: Put checkmark in box -or- 2 x 10 Rafters Spaced 24")*

Minimum 1x \_\_\_\_\_ ridge board  
*(example: 1 x 12)*

Sheathing \_\_\_\_\_  
*(example: 1/2" exterior plywood)*

Roof covering \_\_\_\_\_  
*(example: Class A 3 tab shingles)*

Underlayment \_\_\_\_\_  
*(example: 1 layer #15 felt)*

12 pitch \_\_\_\_\_

Ceiling Insulation \_\_\_\_\_  
*(If heated - example: R-38)*

2x \_\_\_\_\_ ceiling joists @ \_\_\_\_\_ O.C.  
*(example: 2 x 8 @ 24" O.C.)*

Double 2x \_\_\_\_\_ top plate  
*(example: 2 x 6)*

Span \_\_\_\_\_  
*(example: 23' 5")*

Ceiling height \_\_\_\_\_  
*(example: 8')*

Siding \_\_\_\_\_  
*(example: lap or T-111)*

Wall sheathing \_\_\_\_\_  
*(example: 1/2" exterior plywood)*

2x \_\_\_\_\_ studs @ \_\_\_\_\_ O.C.  
*(example: 2 x 6 @ 24" O.C.)*

Cont. 2x \_\_\_\_\_ sill plate  
*(example: 2 x 6 decay resistant)*

Wall Insulation \_\_\_\_\_  
*(If heated - example: R-20 Fiberglass Batts)*

Foundation Insulation \_\_\_\_\_  
*(If heated - example: R-10)*

Footing size \_\_\_\_\_ x \_\_\_\_\_  
*(example: 8" x 16")*

**Building Section**

Provide roof tie downs  
Solid 2x blocking between rafters that are 2x12 or greater

1x4" collar ties @ 48" o.c.

Span

Note: Pre-engineered roof trusses w/truss clips may be used in lieu of roof structure shown.

Diagonal wind bracing or braced wall panels @ corners and each 20' of wall.

Max. 10' wall height

Concrete Encased Ground required for new service

**Check one**

Foundation Detail A

Foundation Detail B  
*(see page 5)*

This handout was developed by the Colorado Chapter of the International Code Council as a basic plan submittal under the 2018 International Residential Code. It is not intended to cover all circumstances. Check with your Department of Building Safety for additional requirements.

**PARKER**  
COLORADO

20120 Mainstreet, Parker, CO 80138  
Phone 303-841-1970 email [building@parkeronline.org](mailto:building@parkeronline.org)

# Single Family Residential One Story Detached Garage

## Foundation Detail A

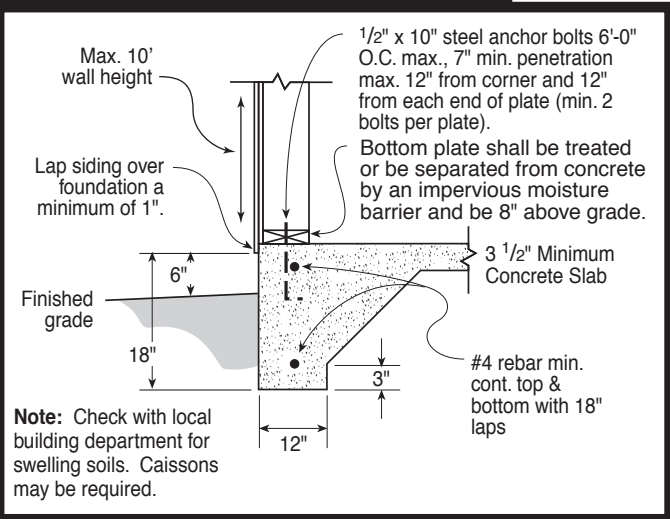

## Foundation Detail B

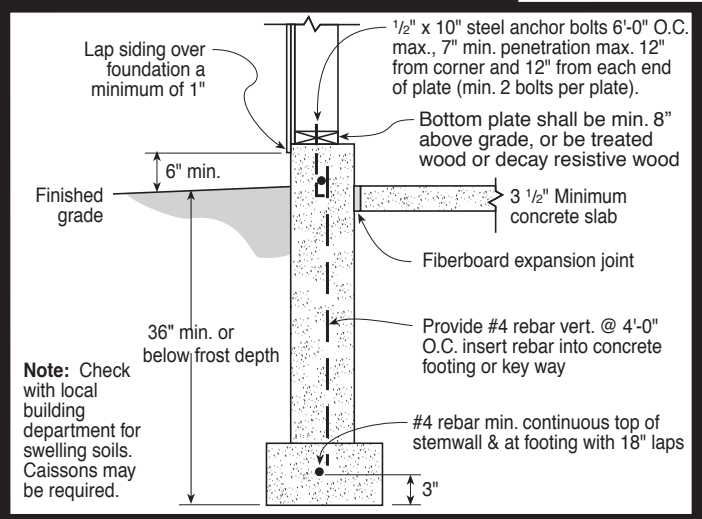

## Braced Wall Panel Detail figure 602.10.6.2

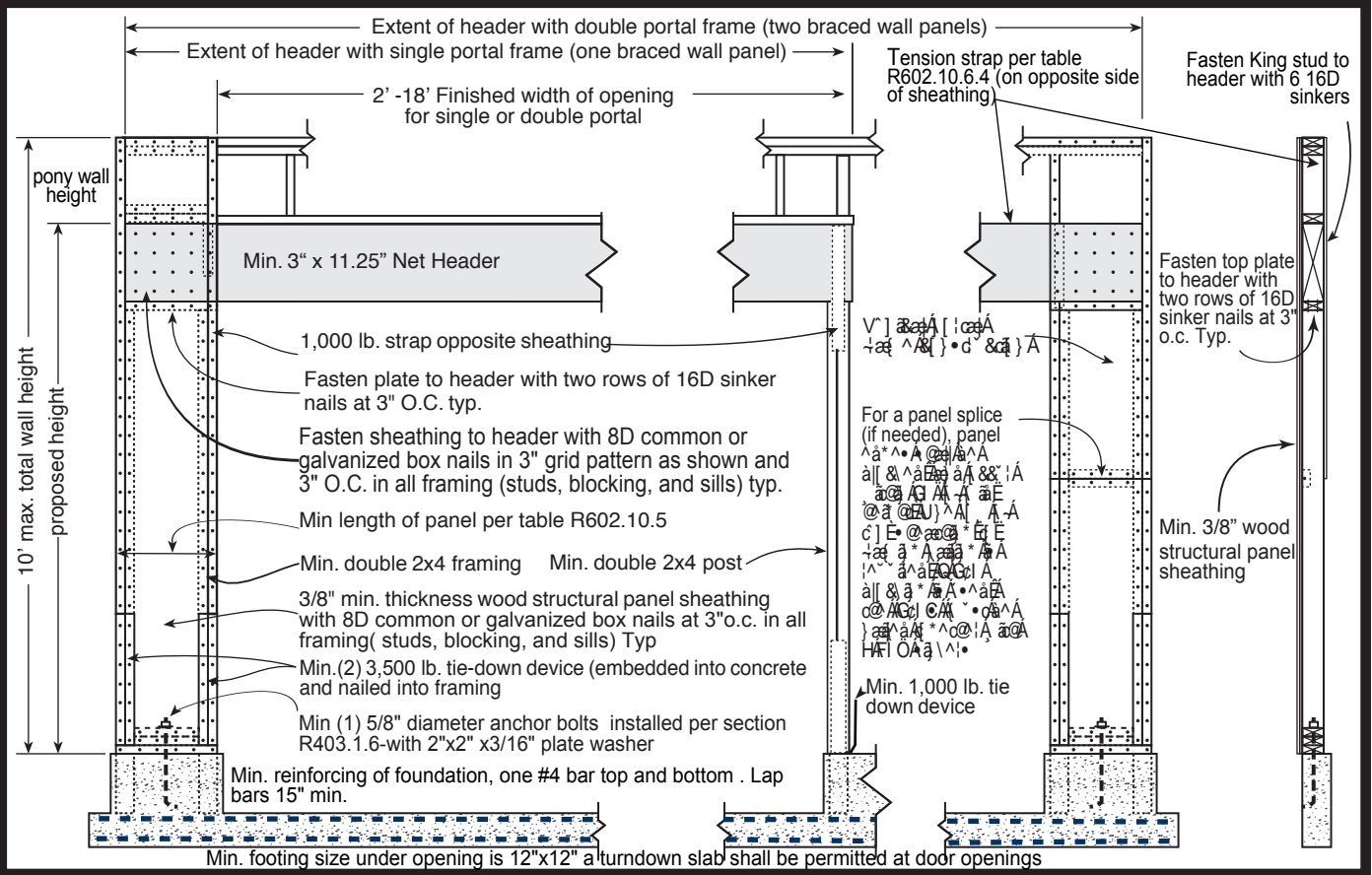

This handout was developed by the Colorado Chapter of the International Code Council as a basic plan submittal under the 2018 International Residential Code. It is not intended to cover all circumstances. Check with your Department of Building Safety for additional requirements.



**PARKER**  
COLORADO

20120 Mainstreet, Parker, CO 80138  
Phone 303-841-1970 email building@parkeronline.org